

MU194-

颜色 (主体)		材质 (主体)		外壳镀层		端子镀层 (接合处)	
1: 黑色	6: 绿色	1: PBT	2: LCP	1: 全金	6: 前镍后锡	1: 1U"	6: 30U"
2: 白色	7: 红色	3: NL9T	4: NL6T	2: 全镍	0: 其它	2: 3U"	0: 其它
3: 贝吉色	0: 其它	5: ABS	6: NL66	3: 全锡		3: 5U"	
4: 灰色		7: PPS	8: PVC	4: 前金后锡		4: 10U"	
5: 蓝色		9: PE	0: 其它	5: 前金后镍		5: 15U"	

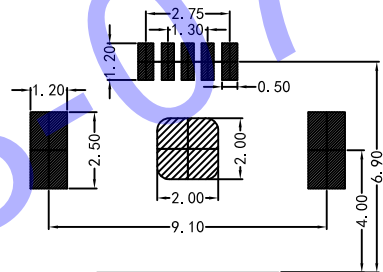

RECOMMENDED PCB LAYOUT
PCB图仅供参考

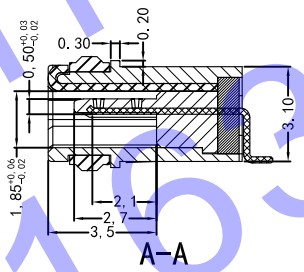
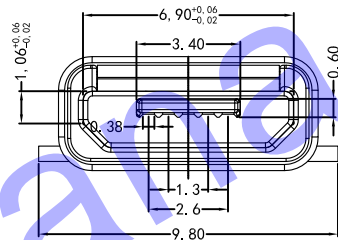
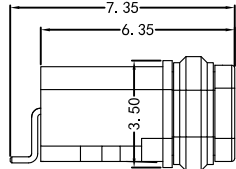
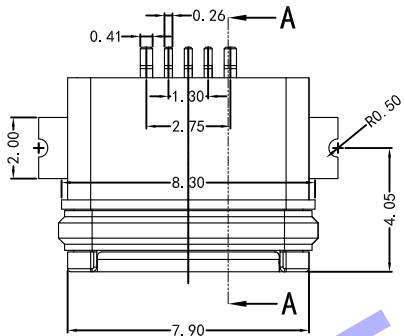
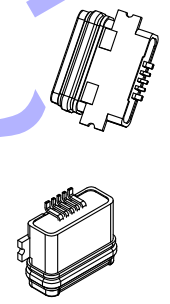

Note:

- Material:
 - 1.1 Housing: High temperature thermoplastic
 - 1.2 Contact: copper alloy, t=0.20mm
 - 1.3 Shell: SUS304, t=0.30mm
 - 1.4 cover: High temperature thermoplastic
 - 1.5 out Shell: SUS304 T=0.25
 - 1.6 Ring: SILICON
 - 1.7 Epoxy: Epoxy
- Specification:
 - 2.1 Current rating: 1,5PIN 2.0A Max/2,3,4PIN 1A Max.
 - 2.2 Dielectric withstanding voltage: 100 V(ac) for 1 min.
 - 2.3 Contact resistance: 30 mΩ, Max.
 - 2.4 Insulation resistance: 100 MΩ, Min.
 - 2.5 Total mating force: 3.57 Kgf Max.
 - 2.6 Total unmating force: 1.0 Kgf Min.
 - 2.7 Temperature range: -30°C~80°C
 - 2.8 Waterproof: IPX68.

TOLERANCES .X ±0.38 .XX ±0.25 ANGULAR ±3°	单位 UNITS MM	版次 REMARK AO	HDC 有限公司		品名 NAME MIRCO USB 5S B型防水压铸型无柱	料号 PART NO. MU194	客户 VERSION	
比例 SCALE 2:1	日期 DATE 2013.5.8			图号 DWG NO.	设计 DRAW BY 杨帆	校对 DISCUSS BY	审核 DISCUSS BY FAN	张号 SHEET 1/1