

RoHs

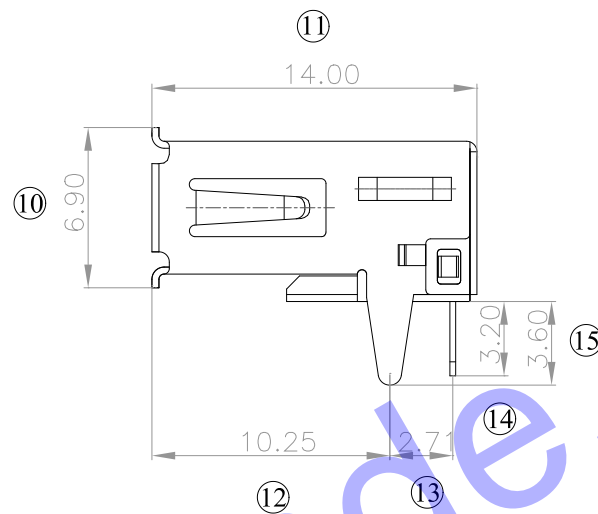
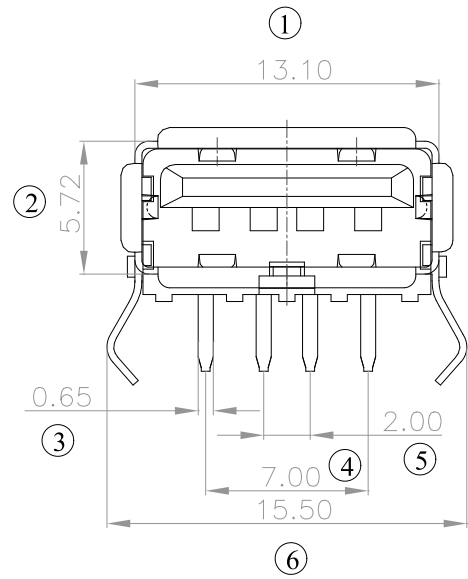

Specification

*Electrical Characteristics:
 Contact Current Rating:1 Amperes.
 Dielectric Withstanding Voltage:AC 500V R.M.S.
 Insulation Resistance:500MΩ Min.
 Contact Resistance:30mΩ Max.

*Environmental:
 Operating Temperature:-40°C~+60°C.

*Mechanical Characteristics:
 Mating Force:3.57kg Max.
 Unmating Force:0.80kg Min.

*Material:
 Housing:PBT UL 94V-0
 Contact:C2680R-H
 (t=0.25mm).Plating Au1u;"3u;"5u;"10u;"
 15u;"30u"
 Shell:SPCC(t=0.30mm).plating NI over all

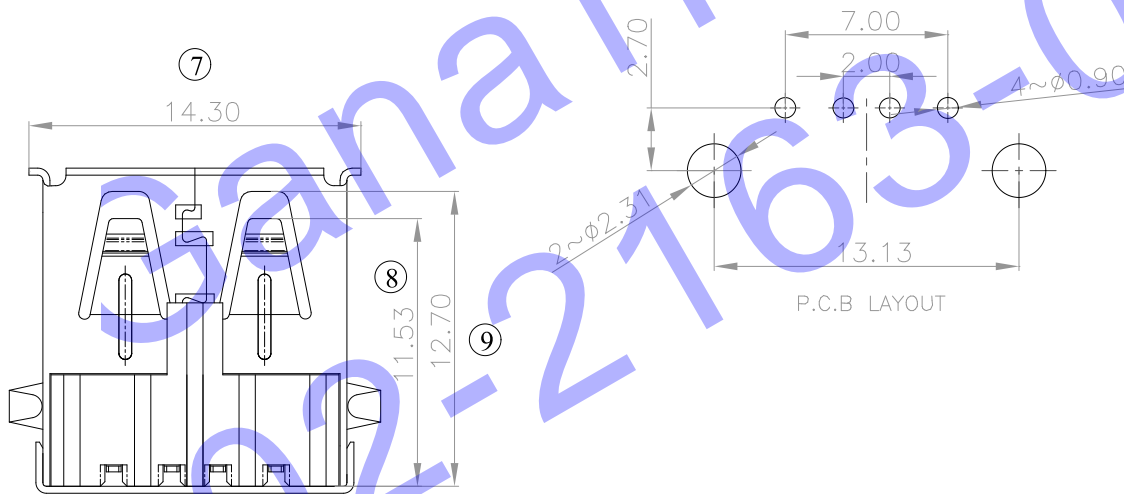

GENERAL TOLERANCE UNLESS OTHERWISE NOTED					
Angle	??m				
X.	? .35	C	品名描述 FILE NAME.	USB A/F DIP 90度 右后盖外扣式	
.X	? .30	料号	PART NO:	REV	A.1
.XX	? .20	DRAWING	CHECKED	APPROVED	
.XXX	? .10	UNIT: mm	SCALE	1:1	SHEET: 1 of 1
A4		材质 MAT,L			