

REV	ECN NO.	DISCRIPTION	CHEKED/DATE	APPD/DATE

NOTES: 1.MATERIAL:
MOLDING: LCP UL94 V-0
CONTACT:COPPER ALLOY.
GOLD PLATED Min ON CONTACT AREA,100u''
Min TIN (LEAD FREE) ON SOLDER AREA,
SHELL: SUS304-H,T=0.30±0.03mm
50u'' NICKEL PLATING OVER ALL.
SHILD:SUS304-H,T=0.12±0.03mm

2.MECHANICAL:
INSERTION: 5~20N.
EXTRACTION: 8~20N AFTER TEST.
DURABILITY: 10000 CYCLES

3.ELECTRICAL:
CURRENT: 5A FOR VBUS;
1.25A FOR GND PIN.
0.25A FOR OTHER.
VOLTAGE: 20 V MAX
WITHSTANDING VOLTAGE: 100V AC R.M.S.
CONTACT RESISTANCE: 40mΩ MAX.
INSULATION RESISTANCE: 100MΩ MIN.

4.ENVIRONMENTAL
TEMPERATURE RANGE -25°C ~ +85°C

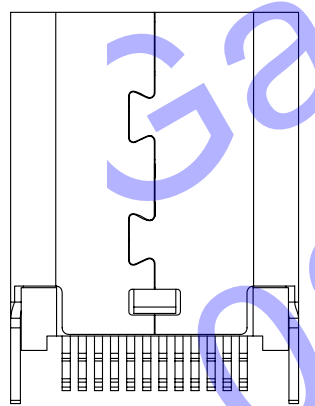
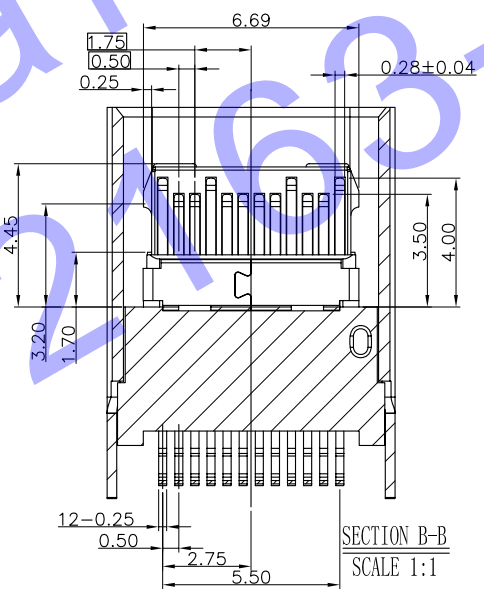
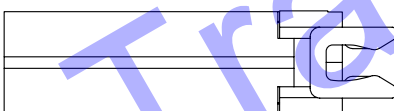
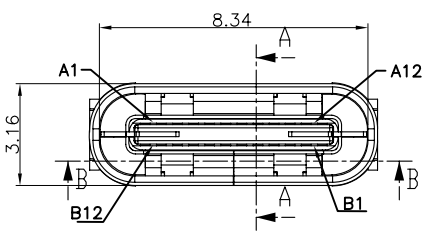
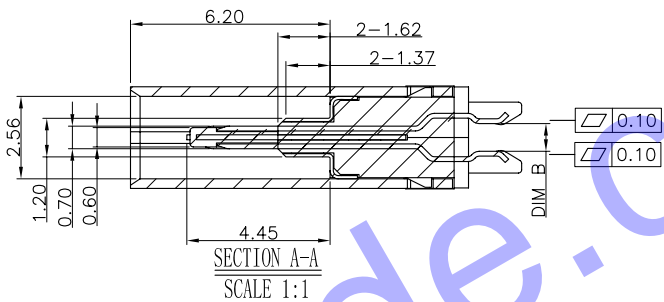
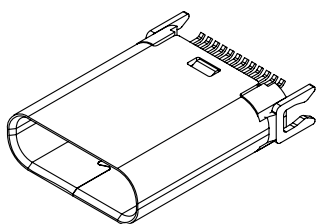
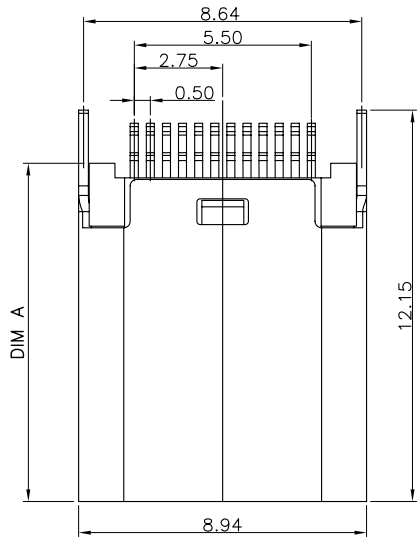

NO	DIM A	DIM B
1	10.5	0.8
2	9.3	1.0
3	10.5	1.0
4	9.3	0.8

H D C 有限公司

. X: ±0.25	. X: ±1°	APP.		DWG NO.	
. XX: ±0.15	. X: ±0.5°				
. XXX: ±0.05	. XX: ±0.02°	CHK.		TITLE	USB 3.1 C TYPE 夹板式母座
UNIT mm		DGN.	15.08.16	SERIES	
SCALE 1:1		DRW.	15.08.16		
REV. A0	SHEET: 1/1				

REV	ECN NO.	DISCRIPTION	CHEKED/DATE	APPD/DATE

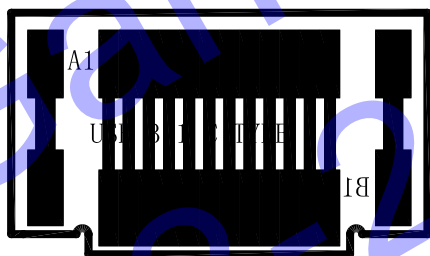
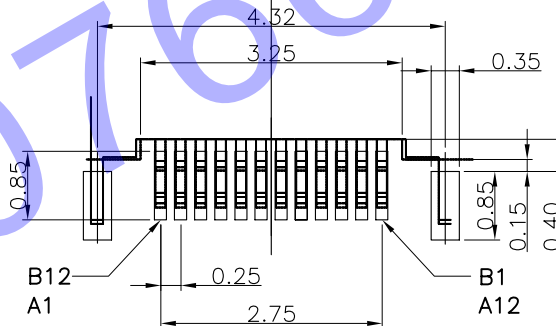
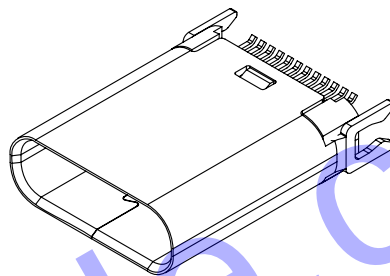
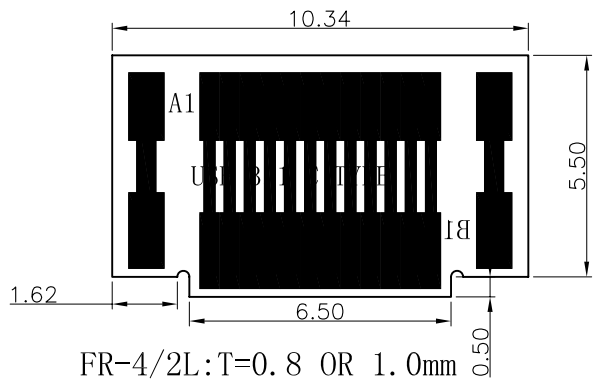

RECOMMENDED P.C.B. LAYOUT (T:0.80mm)
TOLERANCE UNSPECIFIED ±0.05mm

H D C 有限公司

. X: ±0.25	. X: ±1°	APP.		DWG NO.	
. XX: ±0.15	. X: ±0.5°				
. XXX: ±0.05	. XX: ±0.02°	CHK.		TITLE	USB 3.1 C TYPE 0.80/1.0夹板母座 PCB LAYOUT
UNIT	mm	DGN.	15.08.16	SERIES	
SCALE	1:1				
REV.	A0	SHEET:	1/1	DRW.	15.08.16

REV	ECN NO.	DISCRIPTION	CHEKED/DATE	APPD/DATE

備註(REMARK)

- 若有未裝滿之零數箱，必須以緩衝材塞滿。
The unfilling-carton must be filled with assuagement.
- 防水袋需用膠帶貼實且封口。
waterproof plastic bag must be folded up.
- 裝滿成品后之外箱，最大堆積箱數：5箱
About the box fully filled with products, the MAX accumulating quantity of boxes is 5.
- 如須貼Bar-code,請依Bar-code作業辦法執行
If barcode lable is required,do it according to the related barcode lable operation standards.

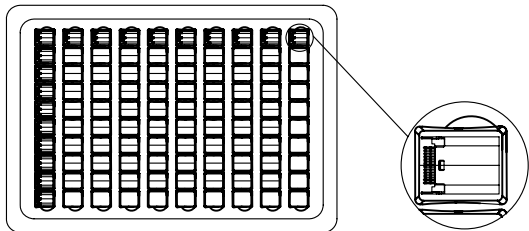

VIEW-1

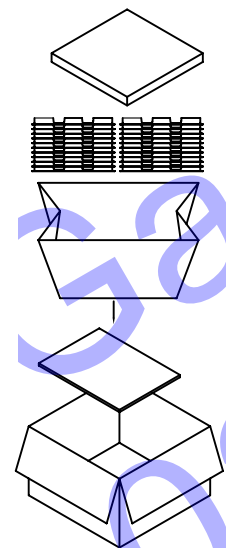

VIEW-2

ITEM NO.	PCS.
Q'TY:	KGS.
N.W.:	KGS.
G.W.:	CM.
M:	

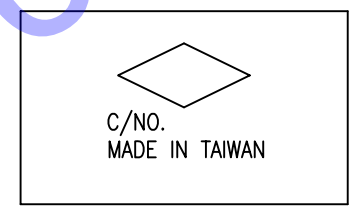

VIEW-3

包裝明細表 (The detail of the packing)						
品料號 (Product No.)	包裝容量 (Packing Capacity)			重量 Weight (Kg)		
	pcs/box	boxs/Carton	Pcs/Box	N.W./Pcs	N.W./Box	G.W./Box
USC2-24FX-KNC2-0X	100	80	8000			

H D C 有限公司					
.X: ±0.25	X: ±1°	APP.		DWG NO.	
.XX: ±0.15	.X: ±0.5°				
.XXX: ±0.05	.XX: ±0.02°	CHK.		TITLE	USB 3.1 C TYPE 0.80夾板母座 包裝圖
UNIT	mm	DGN.	15.08.16	SERIES	
SCALE	1:1				
REV.	A0	DRW.	15.08.16		
SHEET: 1/1					

USB TYPE-C FULL-FEATURED RECEPTACLE INTERFACE PIN ASSIGNMENTS

PIN	Signal Name	Description	PIN	Signal Name	Description
A1	GND	Ground return	B12	GND	Ground return
A2	SSTXp1	Positive half of first SuperSpeed TX differential pair	B11	SSRXp1	Positive half of first SuperSpeed RX differential pair
A3	SSTXn1	Negative half of first SuperSpeed TX differential pair	B10	SSRXn1	Negative half of first SuperSpeed RX differential pair
A4	VBUS	Bus Power	B9	VBUS	Bus Power
A5	CC1	Configuration Channel	B8	SBU2	Sideband Use (SBU)
A6	Dp1	Positive half of the USB 2.0 differential pair-Position 1	B7	Dn2	Negative half of the USB 2.0 differential pair-Position 2
A7	Dn1	Negative half of the USB 2.0 differential pair-Position 1	B6	Dp2	Positive half of the USB 2.0 differential pair-Position 2
A8	SBU1	Sideband Use (SBU)	B5	CC2	Configuraation Channel
A9	VBUS	Bus Power	B4	VBUS	Bus Power
A10	SSRXn2	Negative half of second SuperSpeed RX differential pair	B3	SSTXn2	Negative half of second SuperSpeed TX differential pair
A11	SSRXp2	Positive half of second SuperSpeed RX differential pair	B2	SSTXp2	Positive half of second SuperSpeed TX differential pair
A12	GND	Ground return	B1	GND	Ground return

REV	ECN NO.	DISCRIPTION	CHEKED/DATE	APPD/DATE

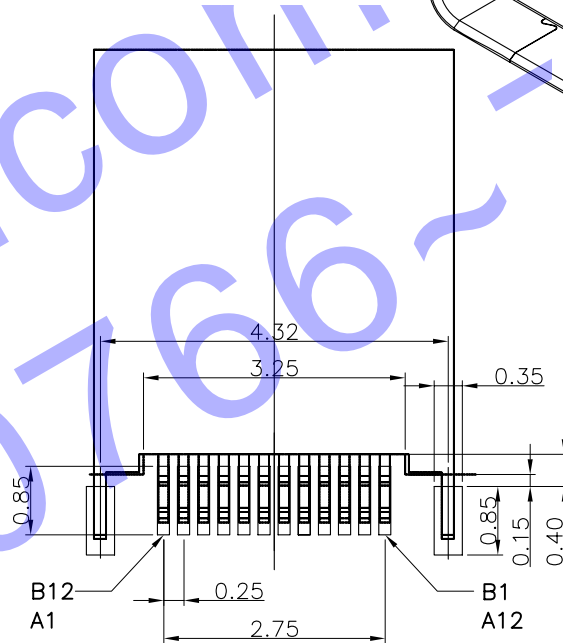
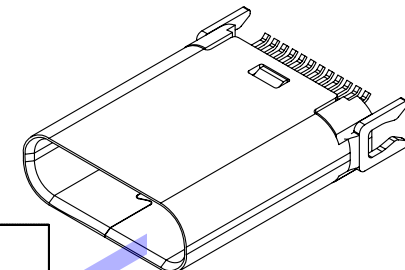

RECOMMENDED P.C.B. LAYOUT (T:0.80mm)
TOLERANCE UNSPECIFIED ±0.05mm

H D C 有限公司

. X: ±0.25	. X: ±1°	APP.		DWG NO.	
. XX: ±0.15	. X: ±0.5°				
. XXX: ±0.05	. XX: ±0.02°	CHK.		TITLE	USB 3.1 C TYPE 0.80夹板母座
UNIT	mm	DGN.	15.08.16	SERIES	
SCALE	1:1		DRW.		
REV.	A0	SHEET:	1/1		