

MU080-3

颜色 (主体)		材质 (主体)		外壳镀层		端子镀层 (接合处)	
1: 黑色	6: 绿色	1: PBT	2: LCP	1: 全金	6: 前镍后锡	1: 1U"	6: 30U"
2: 白色	7: 红色	3: NL9T	4: NL6T	2: 全镍	0: 其它	2: 3U"	0: 其它
3: 贝吉色	0: 其它	5: ABS	6: NL66	3: 全锡		3: 5U"	
4: 灰色		7: PPS	8: PVC	4: 前金后锡		4: 10U"	
5: 蓝色		9: PE	0: 其它	5: 前金后镍		5: 15U"	

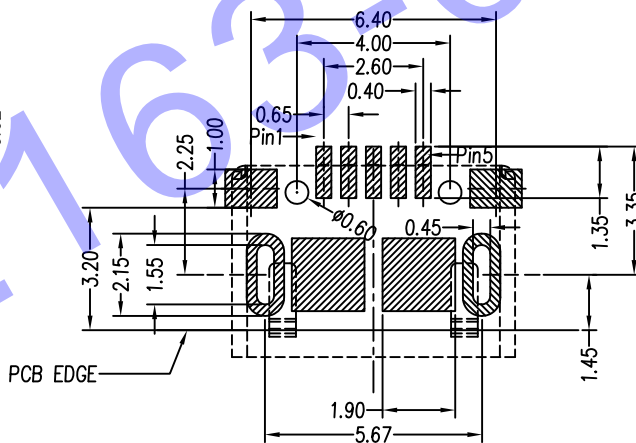
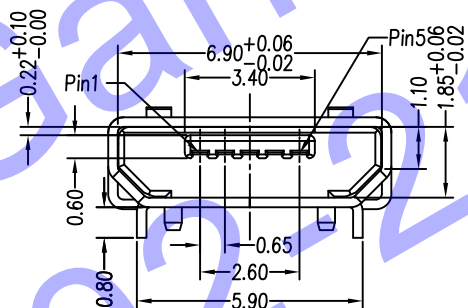
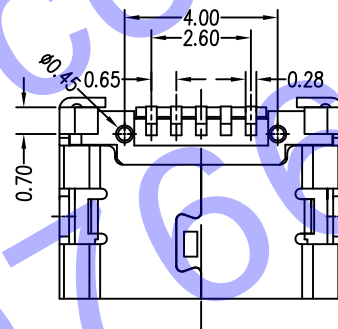
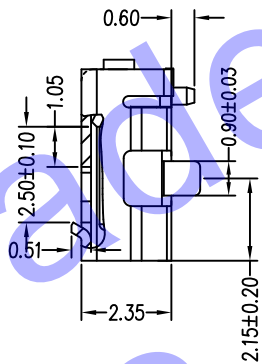
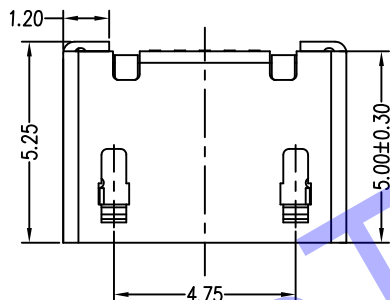
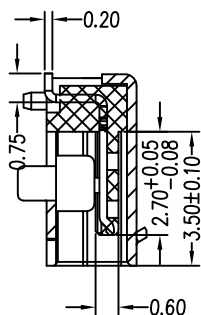
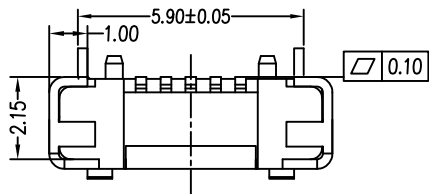

Note:

1. Material:

- 1.1 Housing: High temperature thermoplastic with g.f, UL94v-0
- 1.2 Contact: copper alloy, t=0.20mm
- 1.3 Shell: copper or SUS304, t=0.25mm

2. Specification:

- 2.1 Current rating: 1,5PIN 1.8A Max/2,3,4PIN 1A Max.
- 2.2 Dielectric withstanding voltage: 100 V(ac) for 1 min.
- 2.3 Contact resistance: 30 mΩ Max.
- 2.4 Insulation resistance: 100 MΩ Min.
- 2.5 Total mating force: 3.57 Kgf Max.
- 2.6 Total unmating force: 1.0 Kgf Min.
- 2.7 Temperature range: -30°C~80°C

RECOMMENDED PCB LAYOUT PCB图仅供参考

设计 DRAW BY	杨帆	审核 DISCUSS BY		HDC电子有限公司	图名 DRAWING NO	MICRO USB B TYPE 前插后贴 5.9 有柱直边	图号 SHEET NO	080-3	日期 DATE	2011.4.15			
校对 DISCUSS BY		比例 SCALE	2:1		客户 VERSION		数量 QUAN		备注 REMARK		版次 REMARK		张号 SHEET