

RoHS COMPLIANT

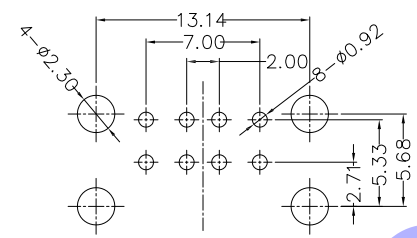
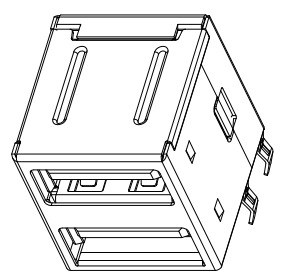
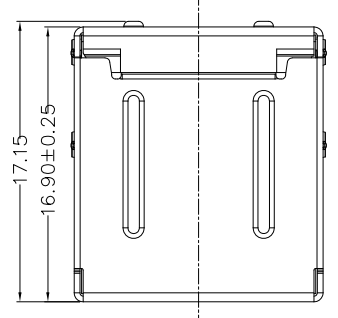

RECOMMEND P.C.B. LAYOUT

NOTES:

- MATERIAL SPECIFICATION:
  - HOUSING MATERIAL:SEE PART NO.
  - SHELL MATERIAL:SEE PART NO. T:0.35mm PLATING:SEE PART NO.
  - BACK COVER MATERIAL:SPCC T:0.35mm PLATING:NICKE.
  - SHRAPNEL MATERIAL:SEE PART NO. T:0.25mm
  - TERMINAL: COPPER ALLOY T:0.25mm PLATING:SEE PART NO.
- ELECTRICAL CHARACTERISTIC:
  - VOLTAGE CURRENT RATING: 1AMP, 30V DC;
  - INSULATION RESISTANCE: 1000MΩMIN;
  - CONTACT RESISTANCE: 30mΩMAX;
  - WITHSTANDING VOLTAGE: 500V AC;
- MECHANICAL:
  - MATING FORCE:3.57 KG MAX
  - UNMATING FORCE:1.02 KG MIN.
- 1X XAX X XNX X XN  
1 2 3 4 5 6 7 8

1:外壳材质代码: A:黄铜C2680,B:磷铜C5191, D:单光铁 E:双光铁

2:外壳电镀代码: A:镀镍12H, B:镀镍24H, C:镀镍48H, D:镀雾镍

3:中夹片材质及电镀代码:A:SPCC 镀镍 E:黄铜 镀镍 I:磷铜 镀镍 K:不锈钢 L:不锈钢 镀镍

4:主体胶芯材质代码: A:PBT, B:LCP, F:PA66

5:主体胶芯颜色代码: 1:白色 2:黑色 3:本色

6:端子材质代码: 1:黄铜C2680, 2:磷铜C5191,

7:端子电镀代码: A:半金锡G/F, B:半金锡3u", C:半金锡15u", D:半金锡30u", E:半金雾锡G/F, F:半金雾锡3u", G:半金雾锡15u", H:半金雾锡30u".

8: 环保代码: N:非环保, R:ROHS, S:SONY, F:ROHS+无齿

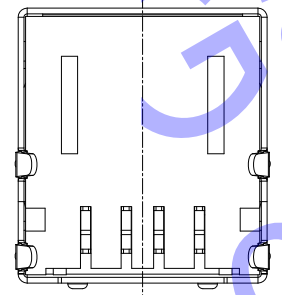
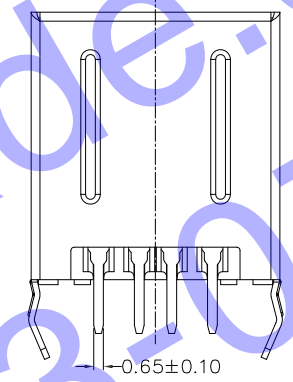
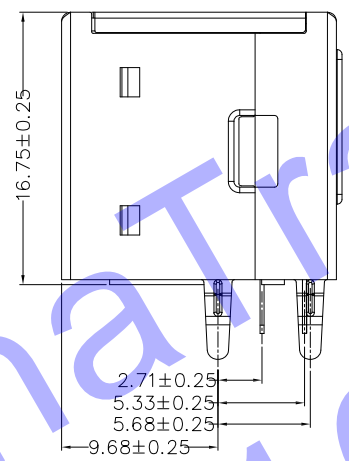
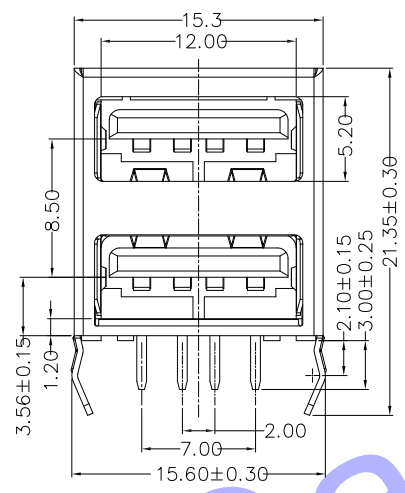

A	QUALITY SYMBOLS		UNIT	SCALE	TOLERANCES	ITEM	DESC	Q'TY	MATERIAL		REMAKS	PART REMAKS	
	■: CRITICAL	☒: MAJOR							DESIGN	DRAWN		REMAKS	SHT
A	图面发行	09'-10-23	mm	3:1	DIM. ±0.30 ANGLE: 3°	APPROVED	CHECKED	DESIGN	DRAWN	PART NO.	-1XXAXXXNXXXN		
REV	DESCRIPTION	DATE								DESCRIPTION	双层 USB AF 90度插板		
										DRAWING NO.	DUB-A07	REV	A

H D C 有限公司

【客户用图】