

HSF

Specification

- 1.Current Rating:1.5AMP
- 2.Contact Resistance:30mΩ max
- 3.Insulation Resistance:1000MΩ min
- 4.Dielectric Withstanding Voltage:500V R.M.S
- 5.Temperature Rating:-40℃ to +85℃

Mechanical Characteristics:

- 6.Mating Force: 3.57kg.min
- 7.Mating Force:1.02kg.min
- 8.Durability: Mandatory: 5000 Cycles

Contact: Phosphor Bronze(T=0.20mm)

Insulator: LCP+30%GF(UL94V-0)

Shell: Brass(T=0.30mm)

Ordering Information

112-09 AFRDXXUN A

Contact Plating
 S0=Gold Flash/Tin
 S1=3u"Gold/Tin
 S2=5u"Gold/Tin
 S3=10u"Gold/Tin
 S4=15u"Gold/Tin
 S5=30u"Gold/Tin
Plating
 B=Black
 W=White
 U=Blue
 R=Red
Packing:
 A=Tray

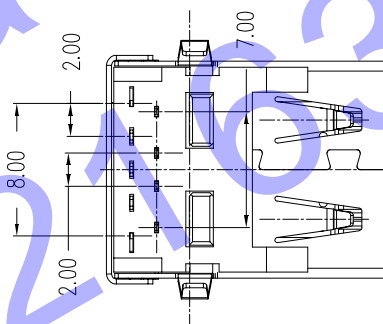
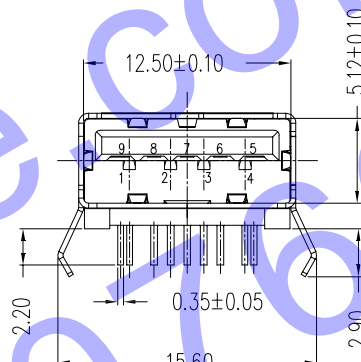
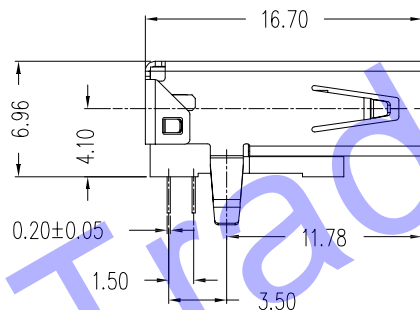
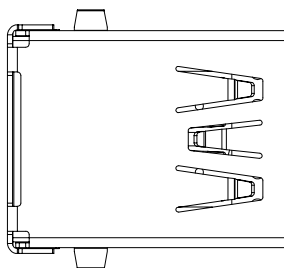

Recommended P.C.B Layout(Top Side)
(PCB BOARD TOLERANCE±0.05)

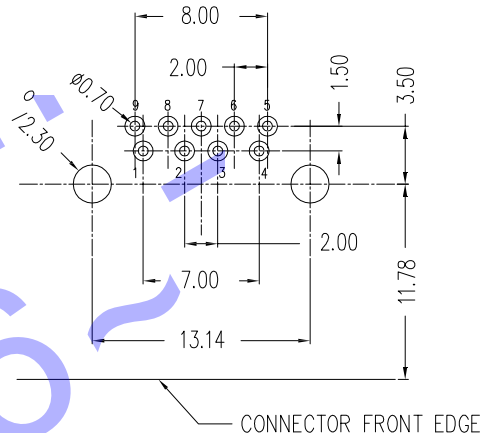

				OPERATION	DRAW	DATE	SCALE	FIT	PART NO.	HDC电子有限公司
				X.X ±0.40	JYHuang	2012/06/29	UNIT	mm	112-09AFRDXXXNA	
				X.XX ±0.25	CHECK	DATE	SIZE	A4	TITLE:	
A0	2012/06/29	NEW		X.XXX ±0.15	APPROVE	DATE	SHEET	1/1	USB3.0A-TYPE FEMALE 90° 16.7mm长 弯脚DIP	
REV	DATE	MODIFICATION DESCRIPTION	CHANGE	Angle ± 3° DIM TOL			PROJ.	Customer NO.		