

F

E

D

C

B

A

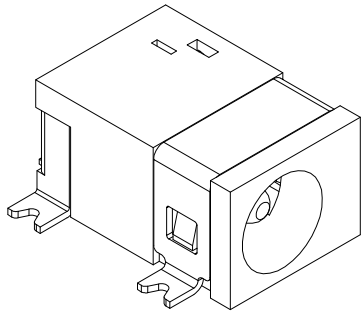

RoHS
Compliant

ZONE	SYMBOL	REVISION	APPROVAL	DATE

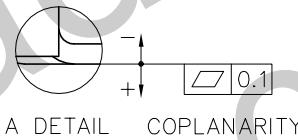
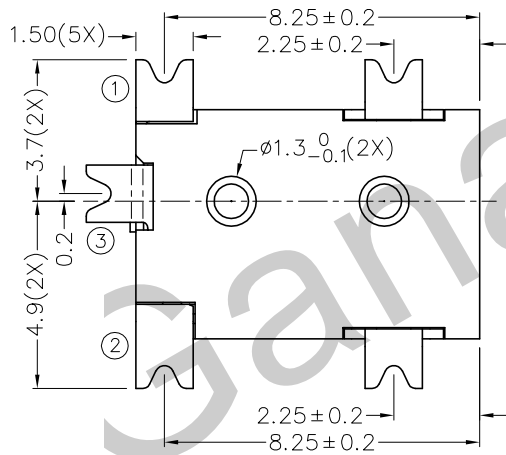
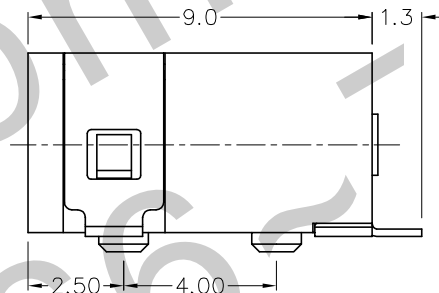
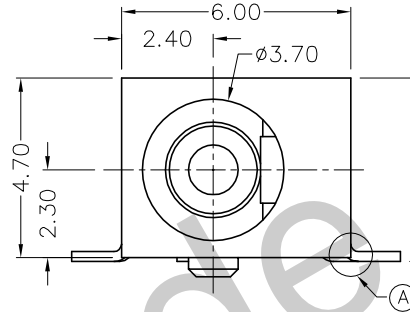
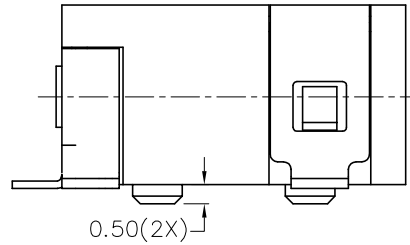

* MATERIAL
CENTRE PIN : COPPER
TERMINAL 1 : BRASS
TERMINAL 2 : COPPER ALLOY
TERMINAL 3 : BRASS
SHIELD : BRASS
HOUSING : PA6T

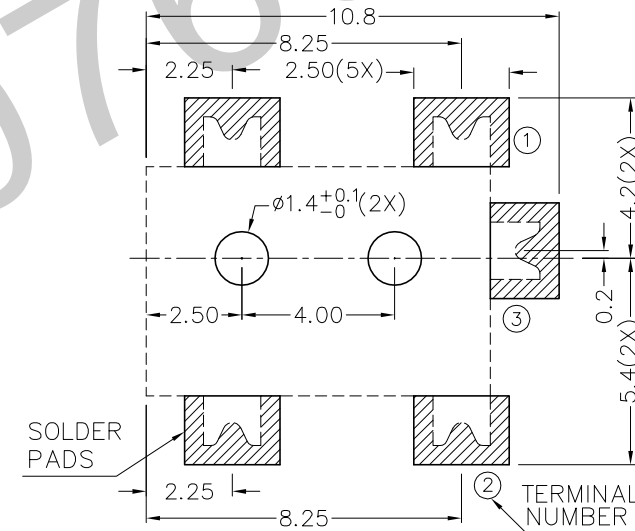

RECOMMENDED
SOLDER PAD LAYOUT
(TOP VIEW)

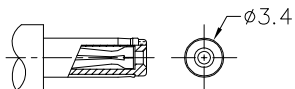

DC MATE PLUG

MODEL NO.	TDC-073DHS
SCHEMATIC	1 3 2
CENTER PIN	ϕ1mm
	ϕ1.3mm



TECHNIK INDUSTRIAL CO.LTD.

DESIGN	T.Y.LI	DATE	14-12-2007	SCALE	5:1
DRAWING	T.Y.LI	DATE	14-8-2010	MATERIAL	*
CHECK		DATE		DWG. NO.	TZ\DC073DHS-PA6T/A
APPROVAL		DATE		SHEET	

PART NAME	HIGH CURRENT SMD DC POWER SOCKET	TOLERANCE UNLESS	0.0±0.2	UNIT:	
PART NO.	TDC-073DHS	OTHERWISE SPECIFIED:	0.00±0.1 0.000±0.05	mm	

F

E

D

C

B

A